



Stop Bucking **Profits** Off
your Stems.

LengthScanPro™ Bucking Optimizer

The **LengthScanPro** offers an accurate, non-contact means of measuring stems as they enter your mill. In the typical configuration, stems are scanned on the fly as they are conveyed into the bucksaws. A solution is then generated and presented to the operator or control system for processing.



HIGHLIGHTS:

Accurately measures stems to ± 1 " at line speeds to 150fpm on the fly, allowing:

- Increased recovery
- Trim to be taken from the small end of the log

A 5% increase in productivity through the bucksaws has been reported by our customers

Specifically designed for close coupled systems

Fully solution generator package can be customized to meet each mills' specific needs

Measurement accuracy is not affected by stem slippage

Low maintenance, with no encoders or photoeyes to clean



LengthScanPro

Accuracy, Simplicity & Affordability

Flexible Solution Generator

The solution generator uses a priority-based bucking formula designed to minimize trim loss. Priorities are entered on a per product basis so solutions can be biased to solve for specific products. Products are defined as specific lengths/diameters.

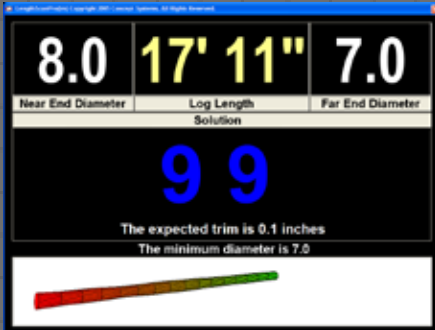

Package Options

The system can be configured with or without diameter scanning. Ask for **LengthScanLite™** for our length-only package.

The system can be configured with or without the solution generator package. Without it, the system will deliver length and/or diameter information to the operator, leaving solution decisions to the operator.

Additionally, the system can be tied directly to the control system in order to automatically sequence stems through the bucksaw, processing the solution developed by the system.

REDUCE WASTE

LengthScanPro is designed to eliminate unnecessary waste at your buck saws. By providing length based solutions, accurate to $\pm 1"$, operators are able to make more precise bucking decisions faster. This improved accuracy enables operators to better utilize the stem, minimizing trim waste. Further-

more, with accurate length information, the stem can be processed such that trim waste is taken off the small end salvaging volume at the large end. The results are impressive. **Our customers have reported production increases of 5%**, based on improved operator decision times and reduced waste.

HOW IT WORKS

LengthScanPro is developed on the advancing Laser RADAR scanning technology. The scanners are configured to look down the conveyor and detect the end of the stem. Using a single axis diameter scanner, once the front edge (or trailing edge depending on

configuration) of the stem is detected, a measurement is captured from the Laser RADARs and the length is calculated. The solution is then generated and presented to the operator, or control system, for processing.

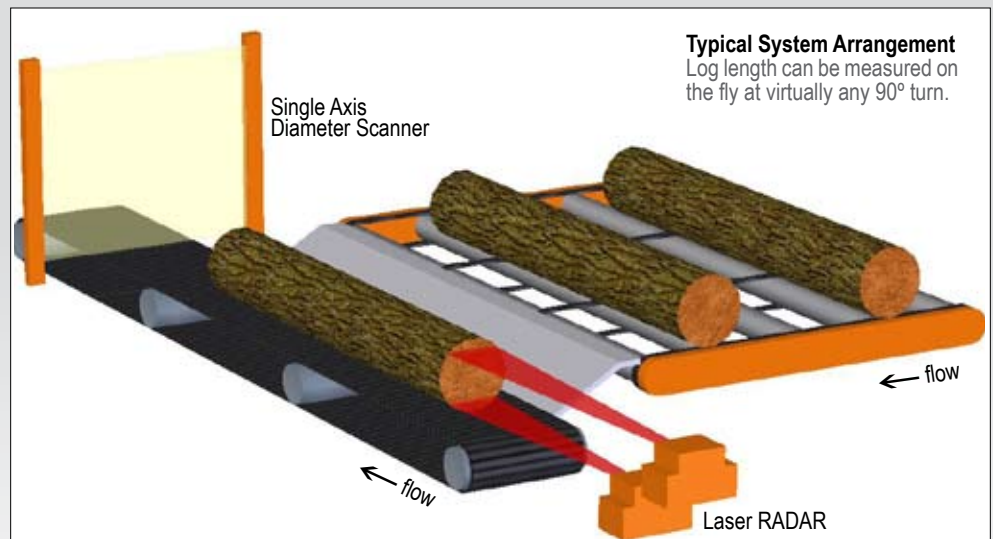

HEADQUARTERS
1957 Fescue Street SE
Albany, Oregon 97322
866-791-8140

